

ATLAS

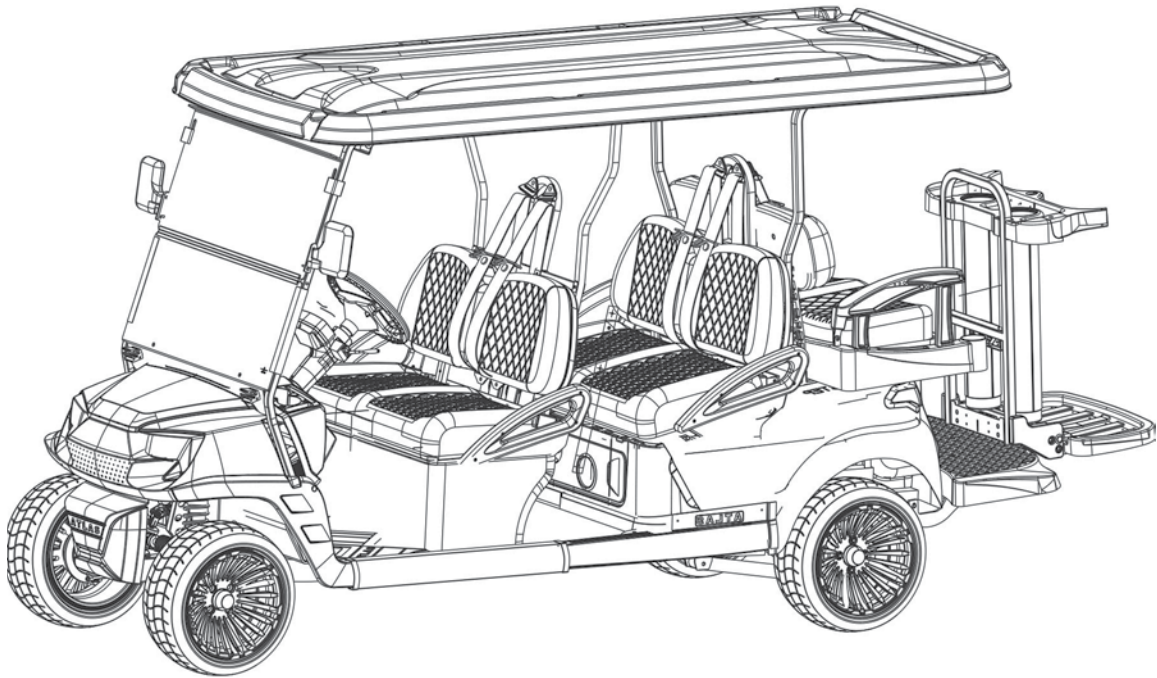

Owners Guide
Atlas Six Passenger

Owner's Guide

Atlas Six Passenger

Model 6N

Atlas Carts
111 County Road 214
Liberty Hill, TX 78642
US: (833) UR-ATLAS
OUTSIDE US: (706) 553-4592

For the latest and most up-to-date version of this owners manual scan the QR code below.



Table of Contents

SECTION

1

Welcome

| | |
|----------------------------------|----|
| Ownership Information | .5 |
| Dealership Information | .5 |

Documentation

| | |
|---|----|
| Model and Serial Number | .6 |
| Design / Engineering Changes by Atlas Carts | .6 |
| Vehicle Modifications by Others | .6 |

SECTION

2

Warranty

| | |
|--|------|
| Atlas Carts Vehicle Warranty | .7–9 |
|--|------|

Safety First

| | |
|--|--------|
| General Information | .10 |
| Safety Signal Words | .10 |
| Rental and Fleet Usage Safety Guidelines | .11 |
| Vehicle Safety Guidelines | .11 |
| Vehicle Safety and Compliance Decals Locations | .12–14 |
| Warning Buzzer | .15 |
| Regenerative Braking | .15 |
| Battery Safety and Recycling | .15 |

SECTION

3

Vehicle Controls and Features

| | |
|-------------------------------------|-----|
| Vehicle Controls Overview | .16 |
|-------------------------------------|-----|

Dash Displays and Indicators

| | |
|---|-----|
| Battery State of Charge (SOC) | .17 |
| Hazard Flasher Button | .18 |
| Radio | .18 |
| USB Interface | .18 |
| Front Storage Box | .18 |
| Key Start Switch | .18 |
| Charging Indicator | .18 |
| Golf Tee Storage | .18 |
| Radio Controls | .19 |

Steering Column Display Alerts

| | |
|---|-----|
| Error Code | .20 |
| Low Voltage Warning | .20 |
| Parking Lights | .20 |
| Turn Signal Indicators | .20 |
| High/Low Beams | .20 |
| Real time State of Charge (SOC) | .20 |
| Real time Speed | .20 |
| Forward/Reverse | .20 |
| Hydraulic Oil Level | .20 |
| Motor Fault | .20 |
| Total Mileage | .20 |

| | |
|---|------------|
| Onboard Battery Charger Safety Warning | .21 |
|---|------------|

Table of Contents

SECTION

4

Vehicle Certifications and Specifications

| | |
|--|-----|
| Federal Communications Commissions | .22 |
| European Conformity | .22 |
| Vehicle Specifications | .23 |

SECTION

5

Vehicle Operation

| | |
|---------------------------|-----|
| Operator Safety | .24 |
|---------------------------|-----|

Daily Pre-Operation Check

| | |
|---|-----|
| Safety Check Overview. | .25 |
| Daily Pre-Operational Checklist | .25 |

SECTION

6

Vehicle Maintenance

| | |
|--|-----|
| Maintenance Safety Overview. | .26 |
| Vehicle Cleaning | .27 |
| Preventative Maintenance | .27 |
| Maintenance & Service Recommendation | .27 |
| Safety Precautions | .28 |
| Lifting the Vehicle Front | .28 |
| Lifting the Vehicle Back. | .29 |
| Checking Tire Pressure. | .30 |
| Wheel Assembly Removal | .30 |
| Wheel Assembly Installation | .30 |

SECTION

7

Onboard Battery Charger

| | |
|------------------------------------|-----|
| Battery Safety | .31 |
| Onboard Charger | .31 |
| Charger Cord Maintenance | .31 |

SECTION

8

Vehicle Towing/Transporting

| | |
|--|-----|
| Preparing the Atlas Cart to be Towed. | .32 |
| Preparing the Atlas Cart to be Transported on a Trailer. | .32 |

SECTION

9

Extended Storage

| | |
|--|-----|
| Storing the Vehicle | .33 |
| Restoring the Vehicle After Storage. | .33 |

Ownership Information

You are now the proud owner of a Atlas Carts personal vehicle. Please take time to read and understand all the information provided in this owner's manual. Knowing how to operate and maintain your new vehicle is the best way to protect your investment. Your new Atlas Cart has been designed to provide you with many miles of reliable transportation.

Understanding all the operating instructions and safety precautions in this manual will prevent the risk of personal injury or property damage.

Owners are responsible to register their vehicles immediately after purchase. Registration of the vehicle will make sure Atlas Carts is able to communicate any necessary information directly to owners.

To register online, visit; <https://www.atlascarts.com/dealers/warranty>

You can also mail your name, address, and vehicle serial number to:

Atlas Carts Warranty Department
111 County Road
Liberty Hill TX 78642

Dealership Information

Contact Atlas Carts customer support anytime for quick answers to your questions and concerns. Your dealer or distributor can provide additional information about:

- Accessories
- Publications
- Replacement Parts
- Technical Support
- Warranty Information

To locate a dealership near you visit: www.atlascarts.com

Model and Serial Number

The vehicle serial number plate is located on the lower part of the dashboard on the passenger side near the right speaker. See the dashboard illustration on page 17.

| Model Number | Battery Type | Production Year/Week | Production Position Number |
|--------------|--------------|----------------------|----------------------------|
| 2N | 02 | 2319 | -000001 |

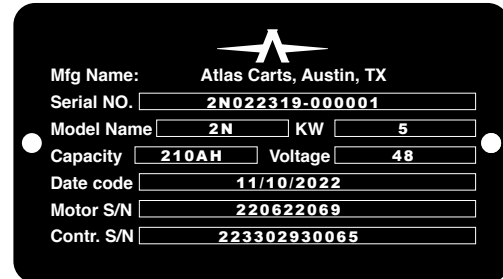

Design/Engineering Changes by Atlas Carts

Atlas Carts may make design changes to any Atlas Carts vehicle without notifying owner or making the same changes to a previously purchased Atlas Carts vehicle.

Atlas Carts is not liable for any errors or omissions in this manual or any incidental or consequential damages that result from the use of any material presented in this manual.

Vehicle Modifications by Others



ANY VEHICLE MODIFICATIONS OR CHANGES THAT RESULT IN IMMINENTLY AFFECTING OCCUPANT SAFETY, WILL RESULT IN DEATH OR SERIOUS INJURY.



MODIFICATIONS TO THE VEHICLE MUST NOT COMPROMISE COMPLIANCE WITH STATE OR FEDERAL REGULATIONS.

Any modifications made to a Atlas Carts vehicle or installation of accessories that are not approved by Atlas Carts may adversely affect the safe operation and performance of the vehicle. Modifications may include, but are not limited to suspension, seating changes, increased speed and cargo capacity. Atlas Carts does not recommend any modification of this vehicle unless the modification is specifically designed and offered by Atlas Carts.

However, if the vehicle is modified, the modifier shall:

1. arrange for the modification to be designed, tested and implemented by an engineer with expertise in vehicles and their safety;
2. maintain a permanent record of the design, testing and implementation of the modification;
3. make appropriate changes to the capacity, plate(s), decals, and operation and maintenance manuals; and
4. apply a permanent and readily visible label on the vehicle stating the vehicle has been modified with the date of the modification and the name of the entity that made the modification.

The entity making any modification becomes the original equipment manufacturer of the modified vehicle, assumes liability for the vehicle, and has the responsibilities listed above.

Refer to the warranty for specific details regarding vehicle modifications.

Atlas warrants to the original purchaser or lessee, that its new vehicle or new component purchased from Atlas or an Authorized Dealer or Distributor shall be free from defects in material and workmanship under normal use and service for the periods stated below, subject to the provisions, limitations and exclusions in this limited warranty.

This limited warranty covers material, workmanship and repair labor cost for the items specifically listed below for the periods listed. Such repair labor shall be performed only by Atlas, its Authorized Dealers or Distributors, or a service agency approved by Atlas. For repairs made by qualified technicians other than Atlas factory technicians or an Authorized Dealer or Distributor, Atlas will provide only the replacement parts or components.

Warranty Time frame

| Subsystem/Component | Warranty |
|---|---|
| Vehicle Main Frame | Lifetime For Material And Workmanship |
| Suspension: Steering gearbox, steering column, shocks, leaf springs and lifted system parts | Two years |
| Major Electronics: Solid state speed controller, e-brake, battery charger, solenoid | Two years |
| Lithium Ion Battery and Battery Management System (BMS) | Five years or 10,000 hours, whichever comes first, retaining a minimum of 70% of its original capacity over that period |
| Pedal Group: Pedal group mechanical assembly, brake cluster assemblies and cables | Two years |
| Seat System: Seat metal parts, seat armrests, rear flip seat system & all other parts of seat except cushions | Two years |
| Electric Powertrain: Electric motor, transaxle and wheel | Two years |
| Body Group: Beauty panels (including dashboard, front and rear cowl), front and rear underbody, structural assembly module and bumper | Two years |
| Seat Cushions: Seat bottom and seat backs | One year |
| All Other Parts and Accessories: safety belt kit, lights, fender flares, limit switches, voltage regulator, F&R switch, windshield, canopy and support structure, side mirrors, center mirror, options and accessories supplied by Atlas | One year |
| Wear Items: Tires, fuses, decals, lubricants, floor lining, mats, pads, brake lining pads, bushings and items that deteriorate, fade or fail due to exposure or ordinary wear and tear | No warranty |

Exclusions

Excluded from any Atlas warranty is damage to a vehicle or component resulting from a cause other than a defect including poor maintenance, neglect, abuse, accident and collision, maintenance adjustments, unreasonable or unintended strain or use, improper installation of accessories, installation of parts or accessories that are not original equipment including Atlas approved or non-approved GPS systems, non-approved alteration, and acts of God. Also excluded from any Atlas warranty are all fuses, filters, decals (except safety decals), lubricants, routine wear items such as engine mounts, bed floor lining, mats, pads, spark plugs, light bulbs, brake pads, brushes, solenoids, bushings, drive buttons, cosmetic deterioration, and items that deteriorate, fade or fail due to exposure or ordinary wear and tear.

The provisions of this limited warranty shall not apply to failure due to the following conditions:

- Batteries
 - Tampering with or opening of the battery case.
 - Intentional overcharging or undercharging of a vehicle.
 - Improper charging of a vehicle due to the use of a battery charger model not approved by Atlas for use with the vehicle.
 - Use of energy management systems that do not allow a minimum of 4 hours of charge time to assure proper charging.
 - Neglect, breakage, freezing, fire, explosion, wreckage, melted terminal posts, the addition of any chemical, or the operation of the battery in an uncharged condition; the installation of the batteries in reverse or recharging in reverse, breakage of containers, covers, or terminal post, or batteries used in applications for which they were not designed.
 - A battery damaged by a defective charger or batteries in vehicles that do not receive proper charging.
 - A vehicle not having an operational charger on a circuit that has the parameters specified in the vehicle operator's manual (the number of operational chargers must equal the number of operational vehicles), or use of an unapproved algorithm.
- Operation outside the manufacturer's stated allowable operating temperature of less than -15 degrees Celsius or more than 55 degrees Celsius. Lack of proper maintenance such as preventive maintenance checks, proper rotation of vehicles in a fleet application, maintaining proper tire pressure and alignment and tightening loose wire connections as outlined in the operator's manual.
- Damages caused by improper installation of the component.
- Failed semiconductor parts such diodes and fuses that are vulnerable to electrical overloads (including lightning) beyond the control of Atlas.
- Damaged charger AC and DC cord set with plug, which is a wear item and subject to user abuse.
- Improper extended storage.

Transportation expenses for warranty services are also excluded from this warranty.

Voiding of Warranty

This warranty shall be void if the vehicle or component is damaged, involved in an accident, abused or used in an unintended manner or shows indications that it has been altered in any way, including, but not limited to, modification of components, braking system, steering, transaxle, or other operating systems of the cart to cause it to perform outside specifications. The warranty is also void if the vehicle shows indications that reasonable or necessary maintenance as outlined in the operator's manual and maintenance and service manual was not performed at the time and in the manner specified in such manuals.

Sole Remedy

Atlas' liability under this limited warranty shall be the repair or replacement, at Atlas' option, of the vehicle or component that Atlas deems to be defective. Replacement shall mean furnishing, during the applicable limited warranty period, a new vehicle or factory-reconditioned vehicle or component that is identical or reasonably equivalent to the warranted product or component at no cost to the purchaser. Repair shall mean remedying a defect in the vehicle or component thereof at no cost to the purchaser during the applicable limited warranty period. Atlas reserves the right to test and recharge any component returned for adjustment. If Atlas elects to repair the vehicle or component, it may provide factory-reconditioned parts or components. All parts and components replaced under warranty shall become the property of Atlas.

Disclaimer

This limited warranty is exclusive. Atlas makes no other warranty of any kind, expressed or implied. The Purchaser and Atlas agree the sole remedy of the replacement or repair of the defective vehicle or component is the sole remedy of the Purchaser. Atlas makes no other representation or warranty of any kind, and no representative, employee, distributor or dealer of Atlas has the authority to make or imply any representation, promise or agreement, which in any way varies the terms of this warranty.

In the event that another pre-printed warranty document, certificate or both offered by or through Atlas at the time of sale of this vehicle (each an "Additional Warranty Document") is deemed to conflict with the limitations or exclusions contained herein, the limitations and exclusions contained herein shall continue to apply to both this limited warranty statement and, to the maximum extent permitted by law, to each Additional Warranty Document.

No Consequential Damages

In no event shall Atlas be liable for any incidental or consequential damages including, but not limited to, loss related to property other than the vehicle, loss of use, loss of time, inconvenience, or any other economic loss.

Some states allow neither limitation on the duration of an implied warranty nor exclusions or limitation of incidental or consequential damages. Therefore, the above limitations or exclusions may not apply to you. This warranty gives you specific legal rights, and you may also have other rights, which vary from state to state.

How To Make A Warranty Claim

To make a warranty claim under this limited warranty, you must present the vehicle or defective component with evidence of proof of purchase date and number of amp hours (if applicable) to an authorized Atlas dealer. For warranty-related communication, contact:

Atlas Carts
Attn: Warranty Department
111 County Road 214
Liberty Hill, TX 78642

General Information

Only operate this vehicle as described in this manual. Speak with your local dealer or distributor for changes, additions, or modifications that are necessary to comply with local laws and regulations pertaining to the use of the vehicle.

Atlas Carts has designed this vehicle to transport people along improved or semi-improved byways. Typical applications include: commercial, industrial, agriculture and personal use as permitted by local laws and regulations.

This vehicle can be used in a variety of usages outside of the manufacturer's intent. Atlas Carts cannot anticipate and warn for every possible usage condition. It is the responsibility of the operator to exercise good sense and judgment and always operate the vehicle in an appropriate manner for the way in which the vehicle is being used.

Safety Signal Words

Signal words (DANGER, WARNING, CAUTION, and NOTICE) and safety messages are used in this manual to alert the owner to important safety messages.

Safety decals are also placed on the vehicle where applicable to notify the owner/operator regarding safe operation and maintenance of the vehicle. Read, understand, and obey all instructions, safety precautions, and safety decals before vehicle operating the vehicle.

NEVER remove any safety decals. Missing, damaged, or unreadable safety decals should be replaced immediately to prevent possible property damage, personal injury, or death. Purchase replacement safety decals from your dealer or distributor.

Understand and follow all laws and regulations for vehicle operation in your area.

Speak with your dealer or distributor if you have questions about any material contained in this manual or the vehicle.

Explanation of Safety Signal Words



DANGER: Indicates an imminently hazardous situation which, if not avoided, will result in death or serious injury.



WARNING: Indicates a potentially hazardous situation which, if not avoided, could result in death or serious injury.



CAUTION: Indicates a potentially hazardous situation which, if not avoided, may result in minor or moderate injury.



NOTICE: identifies a potentially hazardous situation which could result in property damage.

Rental and Fleet Usage Safety Guidelines

Atlas Carts recommends that vehicles used as rentals or as part of a fleet follow the following guidelines for safe service.

- Vehicle operation areas must be approved and all possible safety hazards identified.
- Operators must be qualified and approved to operate the vehicle.
- Provide instruction to operators on safe vehicle operation.
- Maintain all vehicles in safe operational condition.
- Be sure that all safety decals are present on the vehicle.

Vehicle Safety Guidelines



It is the responsibility of the vehicle owner to read and fully understand the capabilities and limitations of the vehicle. The vehicle owner is liable for the safe use of this vehicle to prevent dangerous situations for the operator, any passengers and other people.

Serious personal injury or death can occur if you fail to comply with the instructions and procedures shown in this owner’s guide.

The vehicle or battery charger can cause flammable materials to ignite. Do not operate the vehicle or battery charger near flammable materials and fumes. The vehicle is not to be used in areas that contain explosive material.

Do not operate the vehicle in storms or when lightning is present in the area. Get out of the vehicle immediately and find a safe shelter area.

Children must always be supervised when in or around the vehicle. Unintended vehicle operation can cause death or serious personal injury.

Do not operate the vehicle when under the influence of alcohol, drugs, medications, or while distracted.



Electrical shorts can cause a fire or electrical shock resulting in death or serious personal injury.

To prevent accidental electrical shorts or shocks while making any repairs, always use insulated tools. Do not make contact between positive voltage and the ground circuit.

Do not loiter in front of or behind the vehicle to prevent being hit by another vehicle.

Only two persons may occupy each bench seat at any time. Do not allow people to ride on any part of the vehicle that is not equipped with a seat. Never let a passenger hold a child in his or her lap when the vehicle is moving.

Atlas Carts recommends that only trained technicians be allowed to service or repair the vehicle. Technicians should have the knowledge and experience in electrical and mechanical repair and are obliged to follow appropriate instructions when performing maintenance, service, or installing accessories.

Safety First

Vehicle Safety and Compliance Decals

Take note of the various Safety Decals that are located in and around the vehicle. Be sure to follow all the instructions on the safety decals to prevent the risk of accidental death, serious personal injury, or property damage.

When cleaning the vehicle, do not use solvents, gasoline, or other chemicals to clean the decals. Do not pressure wash decals. Instead, use a soft moist cloth to gently remove any accumulated dirt that may obscure the information printed on the decals.



WARNING

Make sure all of the safety and operation decals are in the correct locations as placed by the manufacturer. Do not remove any of the safety decals. Always re[place any safety and operation decals that are missing or damaged.

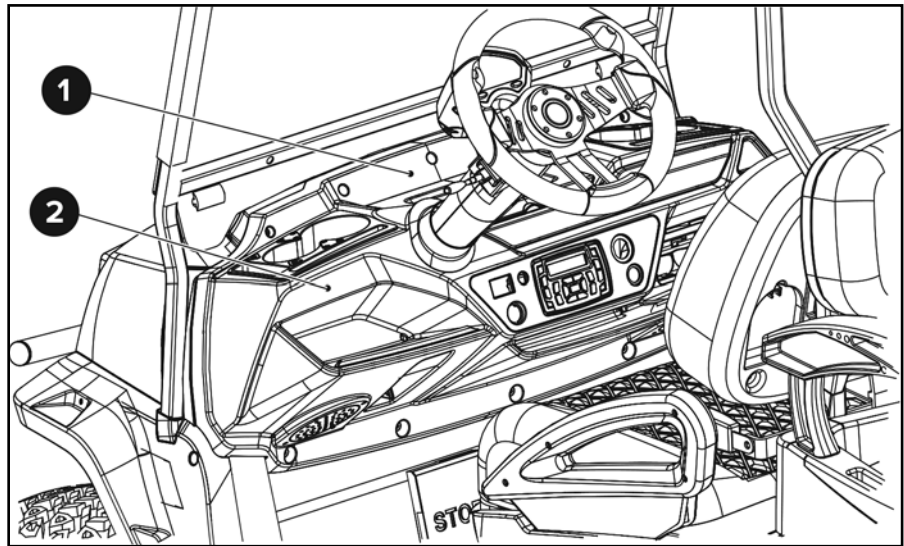

WARNING

1

SERIOUS INJURY OR DEATH MAY OCCUR WITH UNINTENDED MOVEMENT, COLLISION, ROLLOVERS OR FALLING OUT FROM VEHICLE
MAXLOAD: 2P = 500 lbs. MAX GRADE: 20%
4P = 900 lbs.

- Only authorized and/or licensed personnel should operate this vehicle
- All operation should follow in compliance with local and state laws
- Unpaved surfaces, high traffic areas and driving near higher speed vehicles should be done with caution
- Do not obstruct traffic with operation of this vehicle

- All occupants should be fully seated before the start and operation of this vehicle
- Maximum occupants per bench seat is two (2)
- Only driver side occupant should operate this vehicle
- Children should not be unattended with vehicle at any time
- Slower speed should be used when making turns and driving on inclined/declined surfaces
- Occupants should keep entire body secure within vehicle while vehicle is in motion
- This vehicle should not be operated under the influence of drugs or alcohol
- This vehicle should not be operated when distracted

OPERATING INSTRUCTIONS

Users should read the vehicle manual and safety warnings to fully understand vehicle operation before use.

2

- Turn wheels in the direction of a clear path.
- Turn key to the ON position
- Only shift to forward or reverse when vehicle is completely stopped

- Pressing on accelerator pedal will cause vehicle to move
- To increase vehicle speed, gradually press accelerator pedal
- Release accelerator pedal and press down brake pedal to "bring" vehicle to full stop

WARNING!

Severe injury or death may occur with unintended vehicle movement!

- Make sure parking brake is engaged when not in operation
- Vehicle should be placed in Neutral when parking
- Turn key to the off position and remove from key hole when not in operation

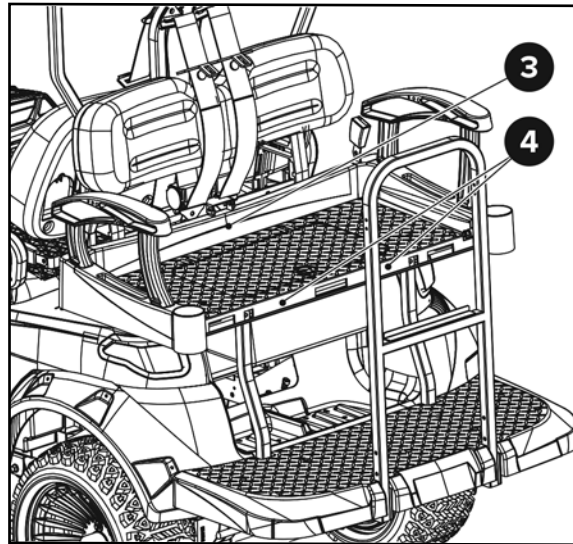

3



WARNING!

DO NOT RIDE IN CARGO BED

- Cargo bed is NOT intended as passenger seating, do not ride in cargo bed
- Severe injury or death may occur to passengers riding in cargo bed

CARGO BED MAX CAPACITY: 150lb/68kg

4



WARNING!

SERIOUS INJURY OR DEATH MAY OCCUR WHEN EJECTED FROM OR FALLING OUT OF VEHICLE.

- Maximum occupants per bench seat is two(2)
- Entire body should be kept within moving vehicle
- Occupants should hold on to grab bars securely while vehicle is in motion



WARNING!

SERIOUS INJURY OR DEATH MAY OCCUR WHEN EJECTED FROM OR FALLING OUT OF VEHICLE.

- Occupants should remain fully seated in vehicle while it is in motion
- Children should not be unattended with this vehicle. Children who may require a child safety seat should not ride in this vehicle

Safety First

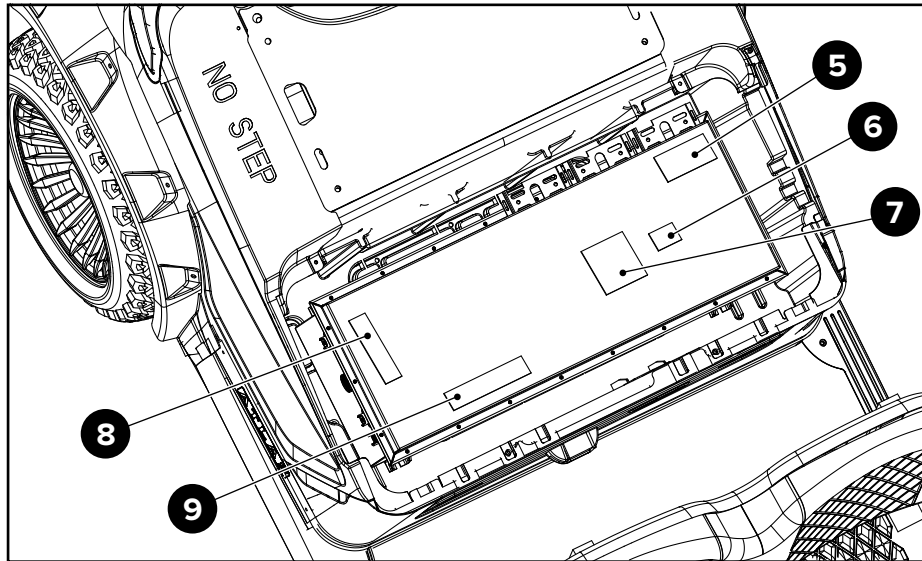

5



6



7



8

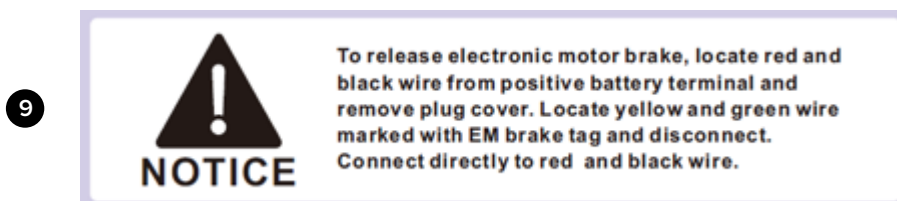

9

Warning Buzzer

The vehicle comes equipped with a multi-purpose buzzer. The warning buzzer makes an audible tone when:

- The Forward / Neutral / Reverse control (FNR) is set to R.

Regenerative Braking

Regenerative braking helps maintain the downhill speed of the vehicle in relation to the accelerator pedal position.

Regenerative braking performance decreases when the battery is fully charged.

Regenerative braking cannot maintain the vehicle speed on an excessive grade (more than 20%). Use the brake pedal to control the vehicle speed.



When the battery is fully charged, a fault code will appear on the display alerting the driver that regenerative braking will be reduced. Use the brake pedal to control the vehicle speed.

Accelerator Pedal Position

Vehicle Speed

Fully Pushed

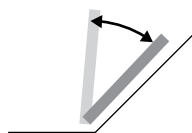

Regenerative braking maintains the speed of the vehicle at the programmed top speed.

Partially Pushed

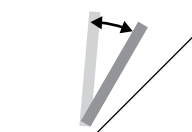

Regenerative braking maintains the speed of the vehicle at a percentage of the programmed top speed in relation to the pedal position.

Fully Released

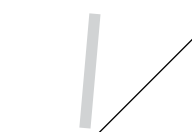

Regenerative braking will slowly bring the vehicle to a stop.

Note: Regenerative braking functions are controlled by controller settings. Contact dealer for more information.

Battery Safety and Recycling

Damage including leaks and explosion can occur if a battery is flooded or submerged. The battery must be replaced.

The battery is not serviceable. NEVER attempt to open the battery. Attempting to open can result in electrical shock, explosion, or fire.

When a battery is no longer able to hold a charge, recycle the battery. It is your responsibility to recycle Lithium-Ion batteries correctly. NEVER discard lithium-ion batteries in your regular municipal trash collection. Contact your dealer or check with your local recycling center.

Vehicle Controls & Features Overview

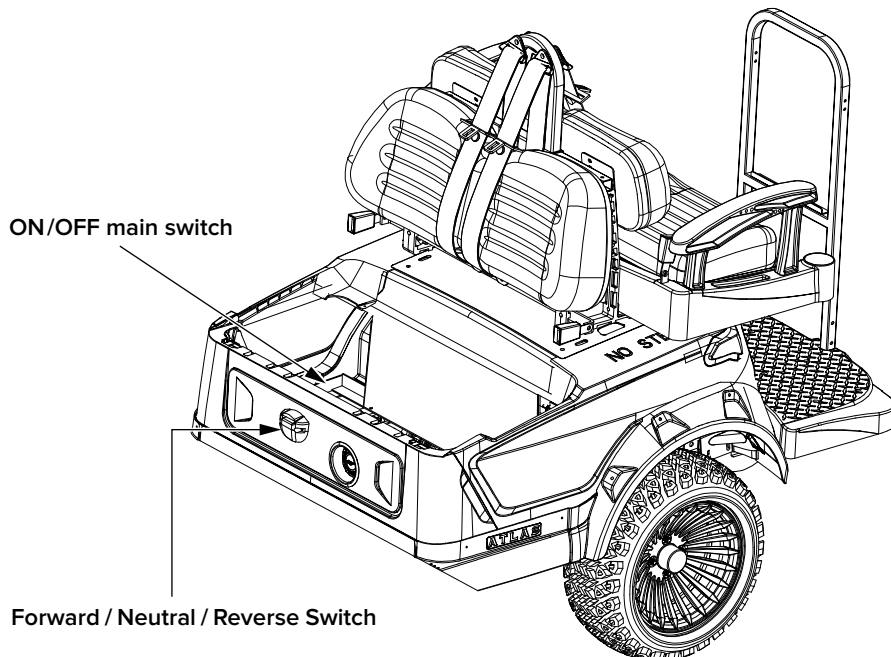
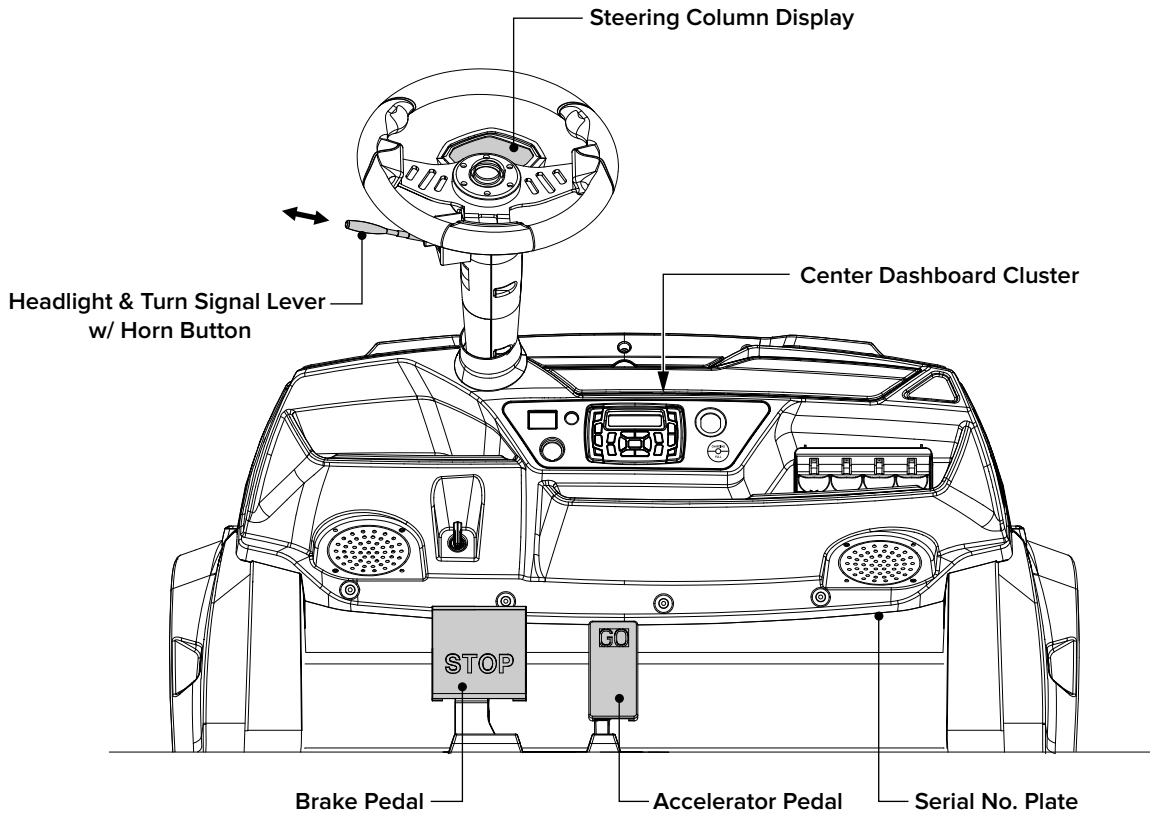

Dash Displays and Indicators

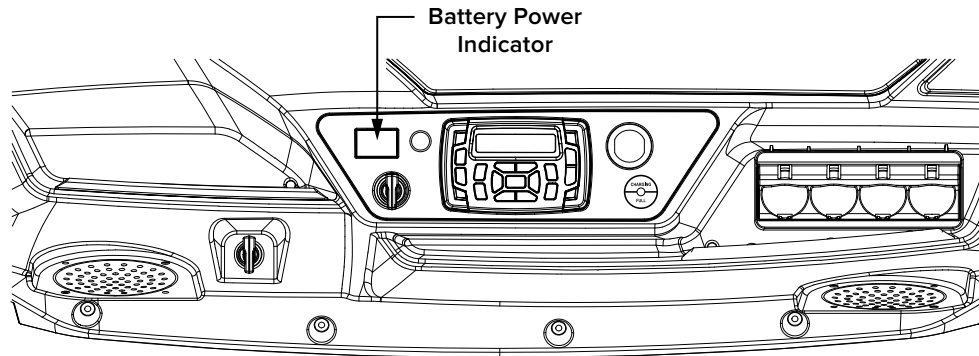

Battery State of Charge (SOC) Display

This display provides a visual report of the Battery State of Charge (SOC) and other information.

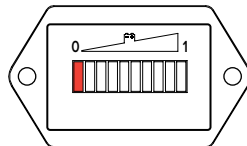

The remaining power is 10%

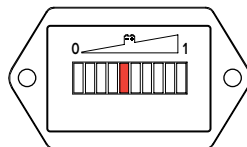

The remaining power is 50%

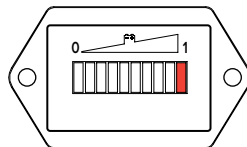

The remaining power is 100%

Dash Displays and Indicators

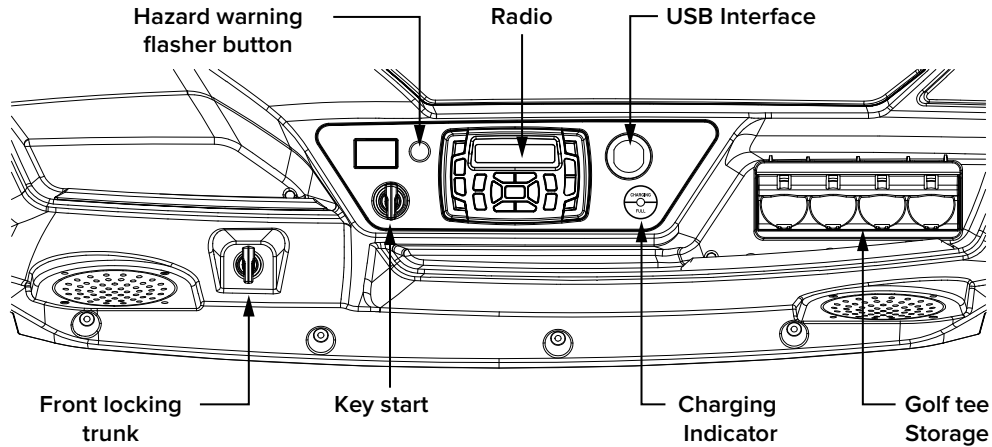

Hazard Flasher Button



Push this button to turn on the hazard warning lights (four-way flashers). This causes all four outside turn signals and both indicators in the instrument panel to flash. Use the hazard warning lights if you need to park in a dangerous area near heavy traffic or if your vehicle is disabled.

Radio

See page 20 for radio instructions.

USB Interface

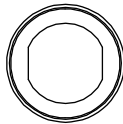

With the key switch in the ON position, the 12V, 2amp USB port supplies power to electronic devices via a USB cable.

Front Locking Trunk



Can be locked/unlocked with the vehicle ignition key.

Key Start Switch

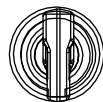

Key start 2-position switch.

- OFF - vehicle is disabled.
- ON - vehicle power on

Charging Indicator



- Flashing green light indicates battery is charging.
- Solid green light indicates fully charged.
- Red flashing light indicates battery is not charging properly and charger connections should be checked.

Golf Ball Holder

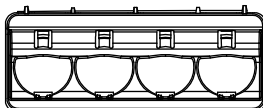

Hold four golf balls and can be removed if desired.

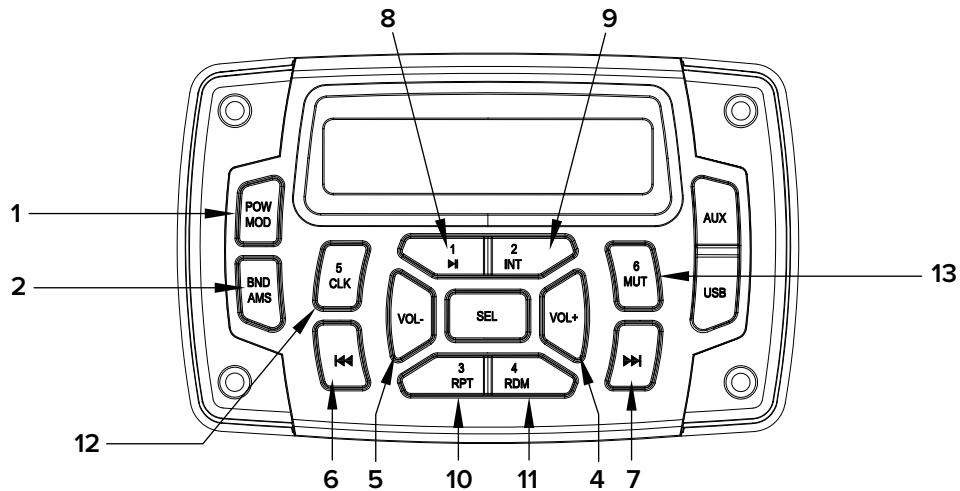

Bluetooth Instructions

To connect bluetooth devices, ensure vehicle key is in “ON” position, press the POWMOD button on the vehicle radio. In your device’s settings, ensure your bluetooth is turned on. Find “ATLAS” device and choose connect.

Radio Functions

- 1 PWR/MOD** Press this button briefly to turn system on. Press and hold for 3 seconds to power system off. When system is on, use this button to toggle between RADIO, AUX IN, & PHONE.
- 2 BND/AMS** Press this button briefly to switch between the three FM and two AM sequences. Press this button to answer incoming calls when connected to hands free calling.
- 4/5 VOL+ / VOL-** Use VOL+ to increase stereo volume level from (0-40).
Use VOL- to reduce stereo volume level from (0-40)
- 6/7 TRACK/TURN BUTTONS** Press left and right red arrow button to move to different radio frequency or play previous or next song on bluetooth device. Hold buttons for three seconds to initiate frequency scanning on radio mode.
- 8 PAU** Press and hold this button on radio mode to save radio frequency in #1 position. When pressing in BT AUDIO mode, this pause bluetooth playing.
- 9 INT** Press and hold this button on radio mode to save radio frequency in #2 position. The INT function is not used in this system.
- 10 RPT** Press and hold this button on radio mode to save radio frequency in #3 position. The RPT function is not used in this system.
- 11 RDM** Press and hold this button on radio mode to save radio frequency in #4 position. The RDM function is not used in this system.
- 12 CLK** Press and hold this button on radio mode to save radio frequency in #5 position. The CLK function is not used in this system.
- 13 MUTE** Press and hold this button on radio mode to save radio frequency in #6 position. Press and hold this button in the BT AUDIO mode to mute the vehicle’s microphone.

Steering Column Display

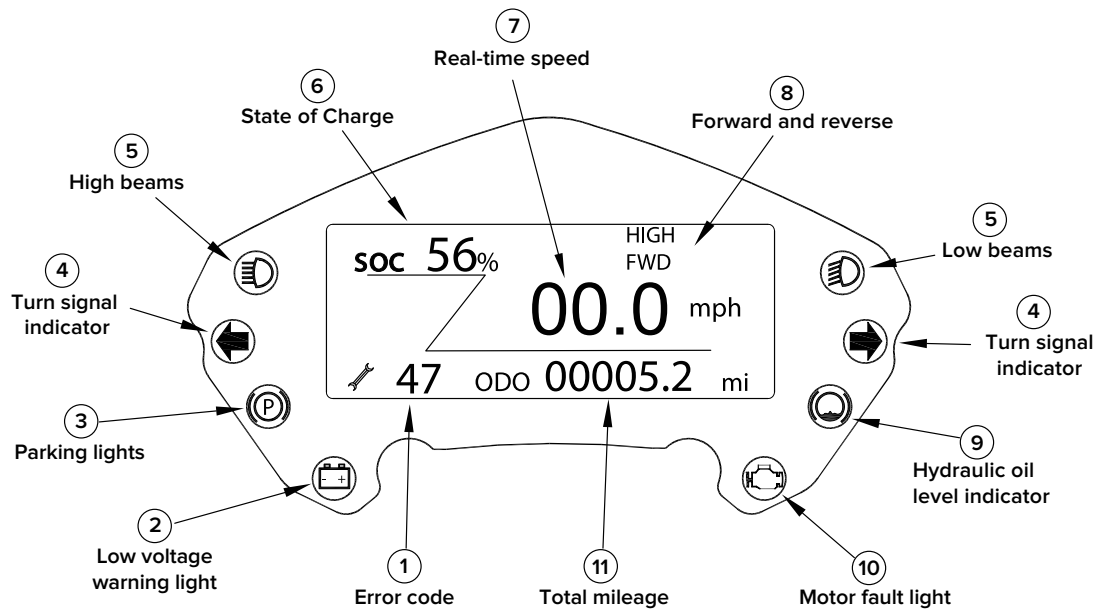
**NOTICE**

The Speedometer is an important tool to understanding your vehicle operation. When the vehicle has an electrical or mechanical malfunction, a beeping sound and flashing maintenance icon (small service wrench) and error code will alert the driver of the specific fault. The driver should immediately stop and arrange for the vehicle to be serviced by their local authorized Atlas dealer.

Some versions of the display will indicate a maximum reading of 99% State of Charge. This is due to the limitation of the display. When 99% is shown, the vehicle is actually at 100% state of charge.

- | | |
|--|---|
| 1 Error Code | Alerts driver of a vehicle malfunction. As soon as safe to do so, park vehicle in safe location and contact your authorized Atlas dealership. |
| 2 Low Voltage Warning | Alerts driver of a low battery voltage occurrence. Vehicle must be charged as soon as possible to avoid damaging electrical components. |
| 3 Parking Lights | Alerts driver that parking brake is engaged. |
| 4 Turn Signal indicators | Alerts driver that turn signal is on. |
| 5 High/Low Beams | Alerts driver headlights are on. Green indicator on right side is for low beams, blue indicator on left is for high beams. |
| 6 Real time State of Charge (SOC) | Alerts driver of the available battery state of charge percentage. |
| 7 Real time Speed | Alerts driver of current ground speed.. |
| 8 Forward/Reverse | Alerts driver of position of direction selector switch. |
| 9 Hydraulic Oil Level | Alerts driver of low hydraulic oil level. As soon as safe to do so, park vehicle in safe location and contact your authorized Atlas dealership. |
| 10 Motor Fault | Alerts driver of vehicle malfunction. As soon as safe to do so, park vehicle in safe location and contact your authorized Atlas dealership. |
| 11 Total Mileage | Alerts driver of total vehicle miles driven. |



Failure to observe the following safety precautions when charging the on-board battery may result in fire, property damage, serious personal injury or death.



Connect the charger power cord to an outlet that is correctly installed and grounded according to all local codes and regulations.

A grounded outlet is necessary to decrease the risk of electric shock – do not use ground adapters or replace the plug.

If an extension cord is needed, only use approved male to female AC power cord. 12/3 SJTOW Heavy Duty, 125 volt, 1875 watt, 15 Amp, AC Cord with 3 Prong Grounded Plug.

Do not touch parts of output connector or battery terminals that do not have insulation. Inspect the power cord for damage before connecting.

Disconnect the AC plug before you make or break the connections to a battery that is charging.

Do not pull the cord to disconnect the charger.

The on-board charger is not user serviceable. Do not open or disassemble the on-board charger.

Do not operate the charger if the AC cord is damaged. Make sure qualified personnel does all repair work to the charger.

Never charge batteries in a hazardous environment.

Do not charge the battery in a wet location. Keep the power cord dry.

Contact dealer for replacement cord or on-board battery charger service.

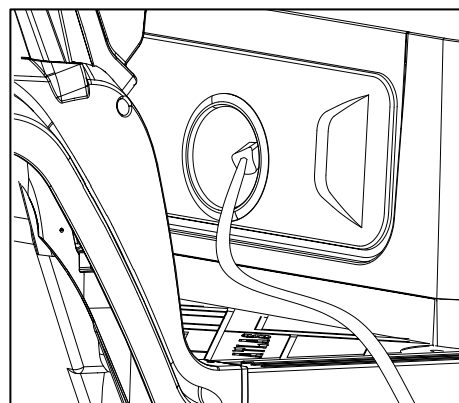

Some Atlas models are designed to not allow charging of lithium battery when temperature of battery is below 32 degrees F (0 degrees C). This is normal and charging will resume when battery temperature is above freezing. Please contact your dealer for more information.

Federal Communications Commission

“This equipment has been tested and found to comply with the limits for a Class B digital device, pursuant to part 15 of the FCC Rules. These limits are designed to provide reasonable protection against harmful interference in a residential installation. This equipment generates, uses and can radiate radio frequency energy and, if not installed and used in accordance with the instructions, may cause harmful interference to radio communications.

However, there is no guarantee that interference will not occur in a particular installation. If this equipment does cause harmful interference to radio or television reception, which can be determined by turning the equipment off and on, the user is encouraged to try to correct the interference by one or more of the following measures:

- Reorient or relocate the receiving antenna.
- Increase the separation between the equipment and receiver.
- Connect the equipment into an outlet on a circuit different from that to which the receiver is connected.
- Consult the dealer or an experienced radio/TV technician for help.

European Conformity

This vehicle is European conformity (CE) certified per EU 2006/42/EC, 2014/30/EU Electromagnetic Compatibility Directive and 2014/35/EU Low Voltage Equipment Directive.

Vehicle Specifications

| | | |
|------------------------------------|---|--|
| Manufacturer Data | Manufacturer | Atlas Carts |
| | Model Name | Six Passenger |
| | Model Number | 6N |
| Dimensions | Vehicle Length | 143.7 in. (3650 mm) |
| | Vehicle Width | 52.36 in. (1330 mm) |
| | Vehicle Height | 74.8 in. (1900 mm) |
| | Ground Clearance | 5.3 in. (135 mm) |
| | Wheel Track Front | 33.86 in. (860 mm) |
| | Wheel Track Rear | 38.19 in. (970 mm) |
| | Wheelbase | 98 in. (2490 mm) |
| | Turning Radius | 173.2 in. (6.1 M) |
| | Step in Height | in. |
| Performance | Forward Speed (On Level Ground) | 20 mph |
| | Operational Temperature Range | -4 degrees F to 122 degrees F (-20 degrees C to 50 degrees C) |
| Electrical | Motor Type | KDS AC 5KW |
| | Motor Horsepower Rating | 6.7 |
| | Battery Type | 210 AH, 48V Lithium-Ion |
| | Battery Quantity | 1 |
| | AC Voltage Input | 85–270VAC |
| | AC Current Input | 12.0A @ 120VAC; 6.1A @220V Max. |
| | Frequency | 50/60Hz |
| | DC Voltage | 68V Max. |
| | DC Current | 25A Max. |
| Mechanical | Brake Fluid | DOT 4 |
| | Transaxle Fluid Capacity | .65 liters; 85W-90GL-5 |
| Vehicle Weight and Load Capacities | Maximum Number of Occupants | 6 |
| | Vehicle Curb Weight Includes Fluids and 48V Lithium 210AH Battery | 1,351 lbs. (613 kg) |
| | Maximum Payload | 794 lbs. (360 kg) |
| | Gross Vehicle Weight Rating (GVWR) Includes total vehicle weight, fluids, battery, passenger, and cargo | 2,145 lbs. (973 kg) |



If the rated capacities of the vehicle are exceeded, property damage, serious personal injury, or death can occur.

Do not exceed the rated capacity of the vehicle. The stated rated capacity is for level surfaces only.

Excess weight in the vehicle can affect the vehicle handling, or cause component failure, resulting in loss of control of the vehicle.

Do not use the vehicle to tow another vehicle or a trailer.

Operator Safety

This section of the manual provides information on the safe vehicle operation. Safe and responsible use of this vehicle is necessary to prevent dangerous conditions for the operator, passengers and other people in the area of operation. Make sure you read, understand and comply with all of this information.



Failure to operate this vehicle as instructed can cause collision, loss of control or tip over resulting in severe injury or death. Follow all safety warnings in this owner's guide.

Do not operate the vehicle where there is a risk of falling objects.

Make sure all occupants are fully seated with seat belts attached at all times.

Do not allow a passenger to hold a child on their lap while the vehicle is in operation.

Stay clear of steep slopes, drop-offs, and unstable surfaces.

Avoid sudden starts, stops, and sharp turns.

Proper vehicle maintenance is very important. Do not endanger yourself or your passengers. Make necessary repairs as soon as possible to maintain maximum vehicle performance.

Before operating the vehicle, check that all passengers can secure themselves in the vehicle.

The operator and all passengers should keep their entire body in the vehicle during operation.

All persons must comply with the warnings and operating instructions. Handicapped persons should not ride in the vehicle.

Passengers must remain seated at all times and hold onto hand holds or handrails when the vehicle is in operation to prevent falls from the vehicle.

The driver must keep both hands on the steering wheel when the vehicle is in operation.

NEVER make a sharp turn when operating at a high rate of speed to prevent falling from the vehicle or vehicle tip over.

Disable the vehicle before leaving the vehicle unattended or during vehicle maintenance.

Children that require a safety seat must NOT ride on the vehicle. Comply with state and local laws pertaining to child safety. The vehicle does NOT meet child safety seat requirements.

Persons, including children, with reduced physical, sensory or mental capabilities should not operate the vehicle unless they have been given supervision or instruction concerning the of the vehicle by a person responsible for their safety. Children should not play with the vehicle.



The vehicle should only be operated from the drivers seat.

Do not operate the vehicle on public roads or highways. Always operate the vehicle in safe designated areas.

Observe local and state laws when operating the vehicle.

Pay attention and exercise caution when operating the vehicle in the presence of other vehicles, in congested areas, or on unimproved surfaces.

Safety Check Overview

Use the daily pre-operational checklist and vehicle performance inspection to inspect the operational condition and performance of the vehicle.

If a vehicle is found to be in bad operational condition, remove it from operation. Removal from operation will prevent more damage to the vehicle and prevent a serious injury.

If the vehicle is removed from operation, contact your dealer to schedule repairs.

Daily Pre-operational Safety Checklist

Safety Decals

- Make sure all safety, regulatory, and marketing decals are correctly installed.
- Clean the decals with a soft moist cloth.
- Replace missing, worn, or damaged decals.

Tires

- Examine for wear and damage.
- Replace worn or damaged tires.
- Make sure that the tire pressure is correct.

Battery

- Make sure that the battery is fully charged.
- Have a trained technician replace missing, worn, or damaged items.

Battery Charger

- Examine the electrical cords for cracks, loose connections, and frayed wires.
- Examine receptacle contacts and plug terminals. Clean as necessary.
- Replace missing, worn, or damaged items.
- Make sure that the battery charger operates correctly.

Vehicle Performance Test

- Front wheels should be turned straight.
- If any wheel has been chocked, remove the wheel chock.
- Listen for unusual noises such as squeaks or rattles.
- Examine the ride and performance of the vehicle.
- Examine the steering. The vehicle must be easy to steer and must not have play in the steering wheel.
- The vehicle must stop smooth and straight. The brake pedal should not go all the way to the floorboard when applied.

Have a trained technician do a brake system check if:

- The vehicle pulls in any direction.
- The brake pedal goes more than half the distance to the floorboard with moderate pressure applied.
- The vehicle does not stop.

Maintenance Safety Overview

Routine and scheduled maintenance of this vehicle is necessary to keep your vehicle in safe and reliable condition. This section of the manual provides safety information for performing maintenance on your vehicle. Make sure you read, understand and comply with all of this information to decrease the risk of personal injury or death.



A wheel or tire that has damage can cause property damage, serious personal injury, or death. Do not attempt to repair a wheel or tire. Contact your dealer for repairs.

Unintended vehicle operation can cause serious personal injury or death. Be sure to turn the vehicle off before leaving the vehicle or during vehicle maintenance.

Atlas Carts recommends that experienced technicians should service or repair the vehicle. Technicians should have experience in electrical and mechanical repairs and follow all instructions when working on the vehicle.

Maximum vehicle performance is achieved by performing regular maintenance and repairs. If problems arise during vehicle operation or during an inspection, operate the vehicle only after repairs have been made.

Do not work on the vehicle powertrain when the vehicle is loaded.

Use insulated tools whenever possible to avoid electrical shorts or electrical shock.

When servicing the vehicle or battery charger, do not wear any loose clothing or jewelry such as rings, watches, chains, etc.

Use a suitable lifting device with a minimum of 1,000 LB. (454 KG) lifting capacity. Do not use the lifting device to support the vehicle in the lifted position. Lift only one end of the vehicle at a time. Always use approved jack stands to support the vehicle and use wheel chocks to support the wheels that remain on the ground.

If any wires are removed or replaced, the replacement wires must match the same gauge and be routed and attached correctly.



Always wear safety glasses when servicing the vehicle. When working near the battery, wearing rubber gloves is recommended.



Before leaving the vehicle or during maintenance of the vehicle, always disable the vehicle.

- Be sure to park the vehicle on a solid level surface.
- Turn the key to **OFF** position.
- Remove the key.
- Set the Forward / Neutral / Reverse switch to **N** position.
- Place chocks against the wheels to prevent unintended vehicle movement.

Vehicle Cleaning

NOTICE

Cleaning the Windshield

Use a soft towel and water to clean the windshield. Use mild soap as necessary. Do not use a household window cleaner.

Cleaning the Vehicle Exterior

Moisture can cause electrical component damage. Do not use a pressure washer or steam cleaner when cleaning the vehicle.

Commercially available automotive cleaners are recommended. Use a sponge or soft cloth for normal cleaning. A garden hose at normal residential water pressure is adequate.

Remove road tar and bugs immediately to prevent possible stains.

Use a non-abrasive wax product.

Cleaning the Vehicle Interior

Proper cleaning of the vehicle seats will help preserve the life of the seats. Use a solution of 10% liquid soap and warm water applied with a soft cloth. Use a soft bristle brush to remove embedded dirt.

Preventative Maintenance

A regular maintenance schedule can prevent excessive vehicle downtime and repair costs. Use these items to keep the vehicle in proper working condition.

- Daily Pre-Operation Safety Checklist
- Vehicle Performance Inspection
- Maintenance Service Schedule

If any problems are found during routine vehicle inspection or while operating the vehicle, make arrangements to have the vehicle repaired. Contact your dealer to schedule repairs.

Maintenance & Service Recommendation

| | |
|-----------|---|
| Daily | Pre-Operational Safety Check (see Section 6) Charge the battery |
| Weekly | Check the Tire pressure |
| Monthly | Clean vehicle |
| 6 Months | Have trained technician: <ul style="list-style-type: none"> • inspect and lubricate the brake system • Inspect the electrical system • Inspect wheel alignment • lubricate front suspension |
| 12 Months | Have trained technician: <ul style="list-style-type: none"> • inspect pedal components • transaxle fluid level • safety decals |

Safety Precautions



When servicing the vehicle, the vehicle may need to be raised.

Never get under a vehicle that is only supported by a jack. The vehicle should be parked on a level and firm surface. Wheels chocks must be used in front and behind wheels that remain on the ground. Use appropriate size jack stands to support the vehicle. Failure to follow these safety precautions could result in injury or death. Use extreme care.

Position the jack and jack stands only as shown in the illustration below.

Lifting the Vehicle Front

- Disable the vehicle by turning the key to **OFF** position.
 - Use a jack and jack stands rated for 1,000 lbs.
1. Place chocks against rear wheels as required to prevent unintended vehicle movement
 2. Place the jack at the center of the front lifting point on the vehicle frame as shown in the illustration below.
 3. Lift the vehicle.
 4. Place jack stands under the frame at the points shown for each side of the vehicle as shown in the illustration below.
 5. Lower vehicle until the vehicle is securely supported by both jack stands.

Lowering the Front of the Vehicle

1. Place the jack at the center of the lifting point on the vehicle frame as shown in the illustration below.
2. Lift the vehicle until the jack stands are clear.
3. Remove the jack stands. **(DO NOT GET UNDER VEHICLE AT THIS POINT)**
4. Lower the vehicle and remove jack.
5. Remove all wheel chocks.

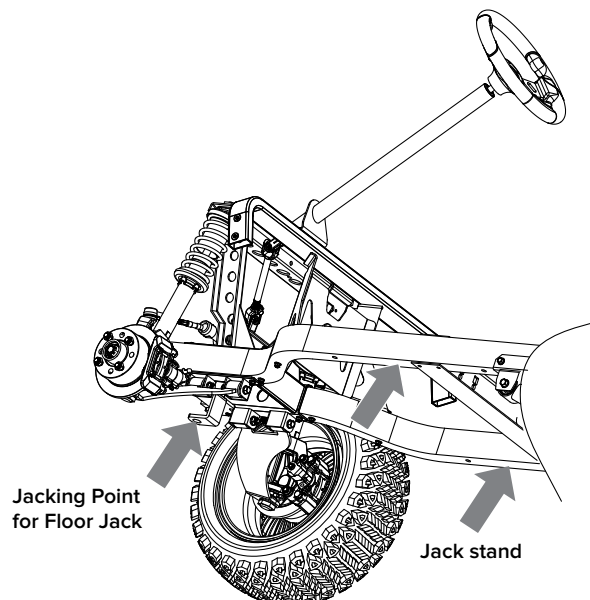

Note:
Position the floor jack below the tow bracket as shown. If a brushguard is installed, use the bottom of the brushguard as the jacking point.

Lifting the Vehicle Rear

Follow the same safety precautions as shown at the top of page 28.

Position the jack and jack stands only as shown in the illustration below.

Lifting the Rear of the Vehicle

- Disable the vehicle by turning the key to **OFF** position.
 - Use a jack stand and jack stands rated for the vehicle weight.
1. Place chocks against front wheels as required to prevent unintended vehicle movement
 2. Place the jack at the center of the lifting point on the vehicle axle as shown in the illustration below.
 3. Lift the vehicle.
 4. Place jack stands under the frame at the points shown for each side of the vehicle.
 5. Lower the vehicle until the vehicle is securely supported by the jack stands.

Lowering the Rear of the Vehicle

1. Place the jack at the center of the lifting point on the vehicle axle as shown in the illustration below.
2. Lift the vehicle until the jack stands are clear.
3. Remove the jack stands. **(DO NOT GET UNDER VEHICLE AT THIS POINT)**
4. Lower the vehicle and remove jack.
5. Remove all wheel chocks.

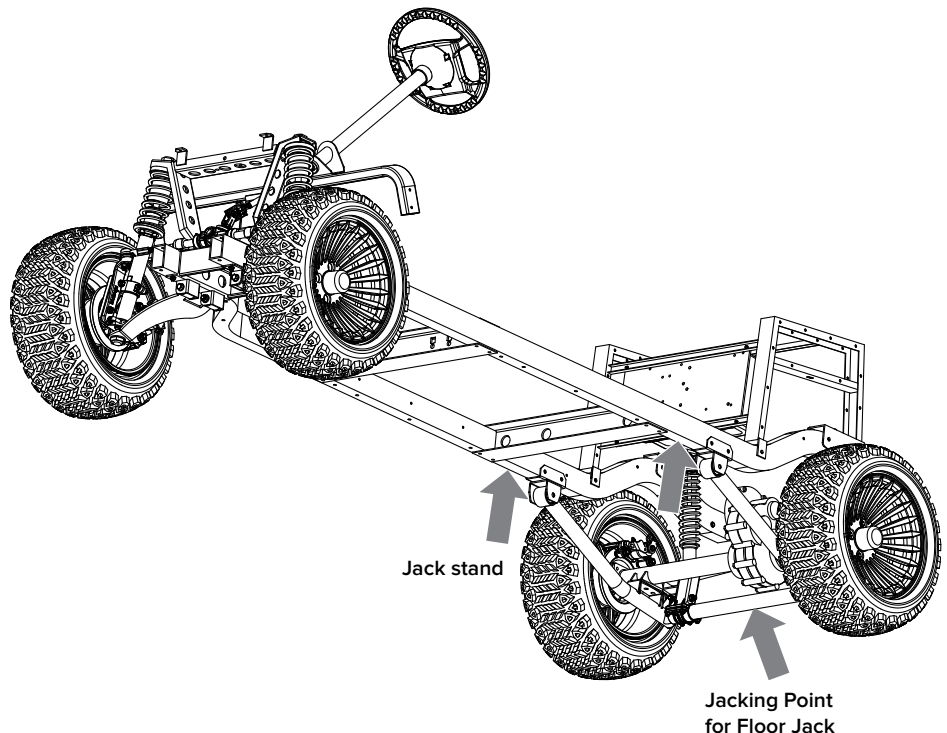

Checking Tire Pressure

To check the tire pressure:

1. Remove the cap on the valve stem.
2. Measure the tire pressure with gauge.
3. Recommended tire pressure for front and rear is 20 PSI for Innova 23x10-14 tires. For all other tires, please contact your authorized Atlas dealer.
4. Adjust tire pressure as necessary.

NOTICE

Correct tire pressure is important for maximum vehicle performance and safety. All tires should maintain the correct tire pressure.

Wheel Assembly Removal

Before attempting to remove a wheel, first disable the vehicle by turning the key to the **OFF** position:

1. Remove the center cap.
2. Loosen all four lug nuts. **DO NOT REMOVE THE LUG NUTS YET.**
3. Lift the vehicle. See pages 28 and 29 for correct vehicle lifting procedures.
4. Remove the wheel assembly.

Correct tire pressure is important for maximum vehicle performance and safety. All tires should be the correct tire pressure.

Wheel Assembly Installation

1. If the vehicle is already in the lifted position, proceed to step 2.
Note: If the vehicle needs to be relifted for any reason, see pages 28 and 29 for correct vehicle lifting procedures.
2. Align the wheel assembly onto the hub.
3. Install all four lug nuts. **Snug up the lug nuts but do not final tighten yet.**
4. Lift the vehicle just enough so the jack stands can be removed.
5. Remove jack stands.
6. Lower the vehicle to the ground and remove any wheel chocks.
7. Final tighten the lug nuts to the recommended torque specification of 93 ft.lbs.
8. If center cap was removed, reinstall the center cap now.

Battery and Onboard Charger

Battery Maintenance

The battery does not require maintenance. Contact dealer for battery service and/or replacement. Keep the battery clean by using a soft cloth to wipe away dirt and accumulated debris.

Onboard Charger

During the charging, it is recommended that the vehicle be parked on a level and flat surface close to the location of the 120V power source.



Do not charge the battery with the key in the ON position. Charging the battery with the vehicle ON, can cause a fire and serious personal injuries. Turn off all accessories and be sure the vehicle key is in the OFF position.



To prevent a fire the cord and connectors should be free of dirt and debris so that connections at the receptacle are clean and tight. Store the battery charging cord in a clean and dust-free location.

Charging with the onboard charger

1. Be sure all accessories are turned **OFF**.
2. Disable the vehicle by placing the key in the **OFF** position.
3. Do not turn off the main switch that is under the front seat.
4. Connect the charger cord to the vehicle charging port first.

5. Connect the cord to an 120V receptacle.

Note: Onboard charger will start within 20 seconds.

- You will hear the solenoid click within 5 seconds.
 - * The charger fan will start within 15 seconds.
 - The State of Charge meter will begin flashing red bars within 20 seconds.
6. When charging is complete, disconnect the AC cord before operating the vehicle. Do not operate the vehicle with the cord connected.

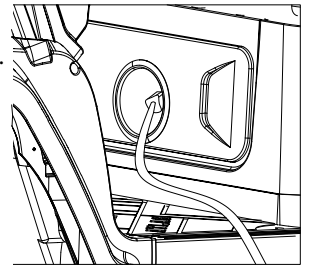

Charger Cord Maintenance

Regularly examine cords and plug ends for any damage or excessive wear.



- Replace cords that have any damage such as cracks or frayed wiring,
- Do not splice cords.
- Do not attempt to repair the cord or plugs.
- If any plug pins are bent, contact dealer for replacement cord.



To prevent property damage, electrical shock, serious injury or death, do not clean or lubricate the plug or receptacle with the cord connected to a 120V power source.

Disconnect the cord from the 120V power source.

Clean the plug the connector ends with electrical contact cleaner.

Vehicle Towing / Transporting



Passengers must not ride in the vehicle while it is being towed by another vehicle or while being transported on a trailer.



Do not stand between the tow vehicle and the vehicle being towed. When a vehicle is being towed, stay off public highways and main thoroughfares.



Use extreme caution when towing the Atlas Cart with another vehicle. Do not make sharp turns. Maintain a slow steady speed of 5 mph (8 km/h).

When trailering a vehicle, make sure the vehicle is secure on the trailer. The vehicle can fall from the trailer and cause property damage, serious personal injury or death.

Preparing the Atlas Cart for Towing

1. **Read and understand the WARNING and CAUTION notes above.**
2. Disable the vehicle by turning the ignition key to the **OFF** position.
3. If necessary, chock the wheels to prevent the vehicle from rolling.
5. Place the Forward / Neutral / Reverse control (**FNR**) to **N**.
5. Turn the main switch (located under the front seat) to the **OFF** position.
6. To manually release electronic parking brake, locate red and black wire coming from the positive battery terminal on the lithium case located under the seat. Remove the plug cover from this red and black wire. Next locate the nearby yellow and green wire marked with the tag labeled "EM brake" and disconnect it from the wire it is connected to. Then connect the yellow and green EM brake wire directly to the red and black wire coming from the positive battery terminal.
7. Securely attach a heavy-duty woven polyester tow strap with a minimum breaking strength of 15,000 lbs. There should be a safety hook on each end. Do not use a rope.
8. Remove the wheel chocks before starting to tow the vehicle.
9. Tow the vehicle under 5 mph (8 km/h).

Preparing the Atlas Cart to be Transported on a Trailer

Note: If the vehicle is operable, it may be safely driven onto a trailer or tow truck bed.

Follow these additional steps if the vehicle is going to be transported on a trailer or flat bed tow truck.

1. Remove the ignition key and keep in a safe place.
2. Remove all cargo and loose belongings from the vehicle.
3. Secure the vehicle to the trailer or truck bed with tie downs or straps.



Before the vehicle is placed in extended storage or during vehicle maintenance, the vehicle must be disabled. Unintended vehicle operation can cause serious personal injury or death.

NOTICE

Do not store the vehicle with a discharged battery. Always have the charger cable connected to the onboard charging system so the battery maintains a full charge. The vehicle main ON/OFF switch can be in the OFF position during extended storage.

Storing the Vehicle

Preparing the vehicle for extended storage:

1. Turn off all accessories.
2. Set the Forward / Neutral / Reverse control (**FNR**) to **N**.
3. Turn the key to the **OFF** position.
4. Remove the key and store in safe place during storage.
5. Place wheel chocks against the wheels.
6. Remove all cargo and personal belongings.
7. Store the vehicle in a dry area, preferably indoors.
8. Check tire pressure and adjust to recommended tire pressure of 20 psi.
9. A drop cloth or suitable cover may be used to keep the vehicle clean.
10. Keep the onboard battery charger cord connected during extended storage. The cord should remain connected to a 120V power source.

**When vehicle is left unplugged for 72 hours or longer, the vehicle will go into sleep mode to conserve battery charge. To “wake up” vehicle, plug vehicle into 110V wall outlet or lift seat and press red button and then hold the green button located on the battery management system directly on the battery for two seconds. You will here the solenoid contact “click” and vehicle will return to normal operation.*

Restoring the Vehicle After Extended Storage

Returning the vehicle to service:

1. Disconnect the charger cord from the 120V power source and then from the vehicle charging port.
2. Make sure the Forward / Neutral / Reverse control (**FNR**) is set to **N**.
3. Switch the main power to the **ON** position.
4. Remove wheel chocks from the wheels.
5. Check tire pressure and adjust to recommended tire pressure of 20 psi.
6. Perform a daily pre-operation safety check. Refer to page 25 for complete pre-operation safety check instructions.
7. Turn the key to the **ON** position.
8. Have a trained technician or dealer lubricate the vehicle.

Atlas Carts
111 County Road 214
Liberty Hill, TX 78642
US: (833) UR-ATLAS
OUTSIDE US: (706) 553-4592
